



Rolling Diaphragm Air Cylinders

The friction free alternative



The "Rolling Diaphragm" Air Cylinder

The advent of the long stroke rolling diaphragm as a means of low-friction dynamic sealing has led to the development of the ControlAir Diaphragm Air Cylinder. These cylinders provide virtually frictionless conversion of pneumatic pressure to linear force, and offer such operating features as:

- Super Sensitivity
- Absolutely No Lubrication Required
- Low Hysteresis
- No Blow-By Leakage
- Wide Temperature Variations.

The rolling diaphragm creates the perfect seal for friction free cylinders. It is a durable, flexible membrane shaped like a top hat with the peak of the hat fastened to the end of the piston and the "brim" clamped to the cylinder cap. Inside of the cylinder this forms a long-lasting frictionless seal between the piston head and cylinder wall. The fabric reinforced elastomer rolling diaphragms are produced utilizing a microprocessor controlled process that is recognized as the leading edge mode of production. Custom diaphragm material design allows for operation of the cylinders at temperatures from -75°F to 400°F.

Ultra Cylinders-Linear Ball Bearings

For applications where the absolute minimum in friction free performance is required, ControlAir has developed the Ultra Cylinder. These cylinders combine the advantages of the rolling diaphragm seal with Grade "A" linear ball bearings and a hardened steel rod to produce virtually zero friction operation. For the ultimate in precise response to small pressure variations, choose "The Ultra."

Modifications

Our standard Diaphragm Air Cylinders are easily modified to meet individual customer requirements. Modifications can include, but are not limited to, diaphragm, bearing, or rod materials, rod configurations, and spring design.

Applications

The performance advantages of our Diaphragm Air Cylinders make them ideal for applications such as Web Tensioners, Dancer Roll Tensioners, Roll Loaders, Valve Actuators, Accumulators, Positioners, and Impact Absorbers to name a few.



Rolling Diaphragm Air Cylinders

Operating Parameters

Single Acting Cylinders

Cylinder Model	Effective Area (inches)	Equivalent Bore (inches)	Stroke (inches)	Initial Spring Force (lbs.)	Spring Rate (lbs./inch)	Weights (lbs.)
S-4-L	4	2.3	1.8	9	4	1.6
S-6-L	6	2.8	2.4	9	4	2.3
S-9-S	9	3.4	2.2	17	4	5.3
S-9-L	9	3.4	3.0	12	4	4.0
S-12-S	12	3.9	2.3	18	6	8.0
S-12-L	12	3.9	3.6	18	6	9.5
S-16-S	16	4.5	2.6	24	8	11.0
S-16-L	16	4.5	4.2	24	8	12.0

Double Acting Cylinders

D-4-L	4	2.3	1.3			2.0
D-9-L	9	3.4	2.5			4.5

Ordering Information Use this coding system to order

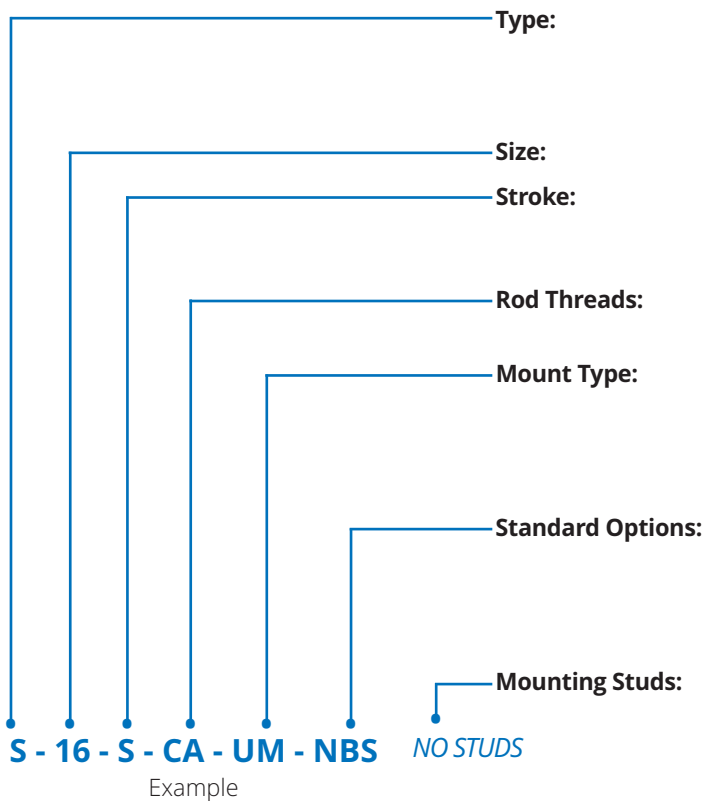

Type:
S = Single Acting Cylinder
US = "Ultra" Cylinder with Ball Bearing
D = (Available Long Stroke Only)
 Double Acting Cylinder (Available Size 4, 9 Only)

Effective Area (Square Inches)

S = Short Stroke
L = Long Stroke
 (See Operating Parameters for selection.)

CA = ControlAir Inc. Standard
SM = National Fluid Power Association Standard

UM = Universal Mount (Standard Mounting p.3)

See page 4 & 5 for optional mounting styles

(To order Rod Clevis see Rod Clevis Dimension section on p.6)

Note: Cap Mounting Studs will be provided only when requested or required by mount option selected. See Page 6.

Standard Options:

NS = No Spring

NB = No Bearing

NBS = No Spring and No Bearing

NOTE: Add to end of ordering number if desired, otherwise leave blank.

Options available for single acting cylinders only.

WITH STUDS = mounting studs on cap and supplied

NO STUDS = mounting studs on cap end not supplied

Note: If cap mounting studs are NOT desired add "no studs"

to end of ordering data. Default is WITH studs. (see page 6).

Not all sizes available as "no studs". Consult factory for availability.

Operating Information

Pressure Airline pressures up to 145 psi (10 BAR)

Temperature -40° to 225°F (-40° to 107° C)

Materials

Cylinder Shell Anodized Aluminum (sizes 4-9), Steel (sizes 12-16)

Head Aluminum (sizes 4-16)

Piston Aluminum (sizes 4-9), Steel (sizes 12-16)

Rod Chrome Plated Steel

Diaphragm Neoprene Rubber with Dacron Fabric

Approximate Forces Determining the force generated by a cylinder

Force = Airline Pressure x Effective Area less Spring Force

Effective Area = Cylinder Size

$$F = P (A_e) - [F_0 + K (S)]$$

F = Cylinder Force

P = Working Pressure

AE = Effective Pressure Area

FO = Spring Force at zero stroke

K = Spring Rate

S = Stroke

Rolling Diaphragm Air Cylinders

Standard Diaphragm Air Cylinders

Shown with Universal Mount

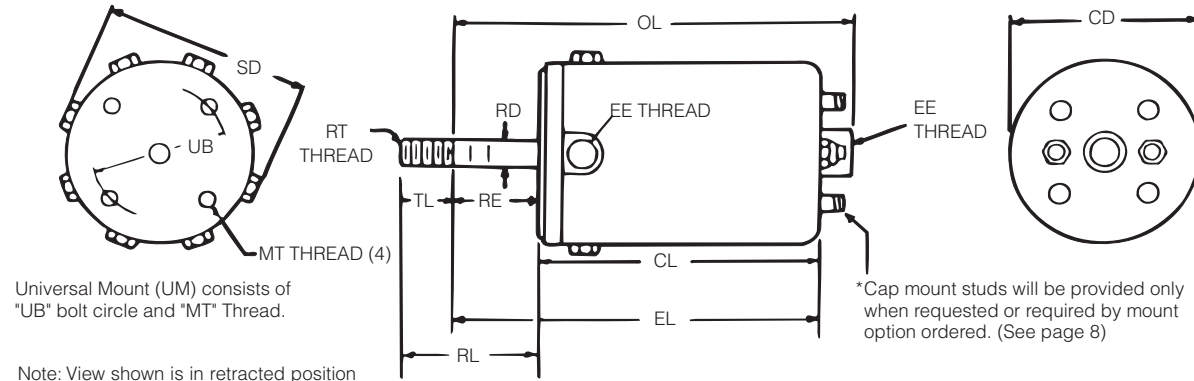

Note: View shown is in retracted position

Cylinder Model	Effec. Area Sq Inches	Stroke Inches	Universal Mount		CA Rod End					SM Rod End							
			CL	CD	SD	EE	UB	MT	EL	RE	TL	RT	OL	RL	RD	EL	RE

Single Acting Cylinders

S-4-L	4	1.8	4.34	2.71	3.02	1/4npt	2.00	1/4-20	6.32	1.98	.75	3/8-24	6.72	2.73	1/2	6.07	1.73	1.00	7/16-20	6.47
S-6-L	6	2.4	5.28	3.27	3.58	1/4npt	2.00	1/4-20	7.22	1.94	.75	3/8-24	7.63	2.69	1/2	6.97	1.69	1.00	7/16-20	7.38
S-9-S	9	2.2	5.31	3.84	4.25	1/4npt	3.00	7/16-14	7.23	1.92	1.00	1/2-20	7.63	2.92	3/4	7.11	1.80	1.12	3/4-16	7.51
S-9-L	9	3.0	6.34	3.84	4.25	1/4npt	3.00	7/16-14	8.03	1.69	1.00	1/2-20	8.44	2.69	3/4	7.91	1.57	1.12	3/4-16	8.32
S-12-S	12	2.3	5.31	4.38	4.79	3/8npt	3.00	7/16-14	7.23	1.92	1.00	1/2-20	7.78	2.92	3/4	7.11	1.80	1.12	3/4-16	7.66
S-12-L	12	3.6	7.28	4.38	4.79	3/8npt	3.00	7/16-14	9.23	1.95	1.00	1/2-20	9.78	2.95	3/4	9.11	1.83	1.12	3/4-16	9.66
S-16-S	16	2.6	6.03	4.99	5.40	3/8npt	3.00	1/2-13	8.09	2.06	1.00	1/2-20	8.64	3.06	3/4	7.97	1.94	1.12	3/4-16	8.52
S-16-L	16	4.2	8.38	4.99	5.40	3/8npt	3.00	1/2-13	10.16	1.78	1.00	1/2-20	10.71	2.78	3/4	10.04	1.66	1.12	3/4-16	10.59

Double Acting Cylinders

D-4-L	4	1.3	4.34	2.71	3.02	1/4npt	2.00	1/4-20	6.32	1.98	.75	3/8-24	6.72	2.73	1/2	6.07	1.73	1.00	7/16-20	6.47
D-9-L	9	2.5	6.34	3.84	4.25	1/4npt	3.00	7/16-14	8.03	1.69	1.00	1/2-20	8.44	2.69	3/4	7.91	1.57	1.12	3/4-16	8.32

Ultra Cylinders with Linear Ball Bearings

US-4-L	4	1.8	4.34	2.71	3.02	1/4npt	2.00	1/4-20	6.69	2.35	.75	3/8-24	7.09	3.10	1/2	6.44	2.10	1.00	7/16-20	6.85
US-6-L	6	2.4	5.28	3.27	3.58	1/4npt	2.00	1/4-20	6.69	1.41	.75	3/8-24	7.09	2.16	1/2	6.44	1.16	1.00	7/16-20	6.85
US-9-L	9	3.0	6.34	3.84	4.25	1/4npt	3.00	7/16-14	8.84	2.50	1.00	1/2-20	9.25	3.50	3/4	8.72	2.38	1.12	3/4-16	9.13
US-12-L	12	3.6	7.28	4.38	4.79	3/8npt	3.00	7/16-14	8.85	1.57	1.00	1/2-20	9.38	2.57	3/4	8.73	1.45	1.12	3/4-16	9.26
US-16-L	16	4.2	8.38	4.99	5.40	3/8npt	3.00	1/2-13	11.16	2.78	1.00	1/2-20	11.69	3.78	3/4	11.04	2.66	1.12	3/4-16	11.57

Shown in inches

The Inside Story on ControlAir Diaphragm Air Cylinders

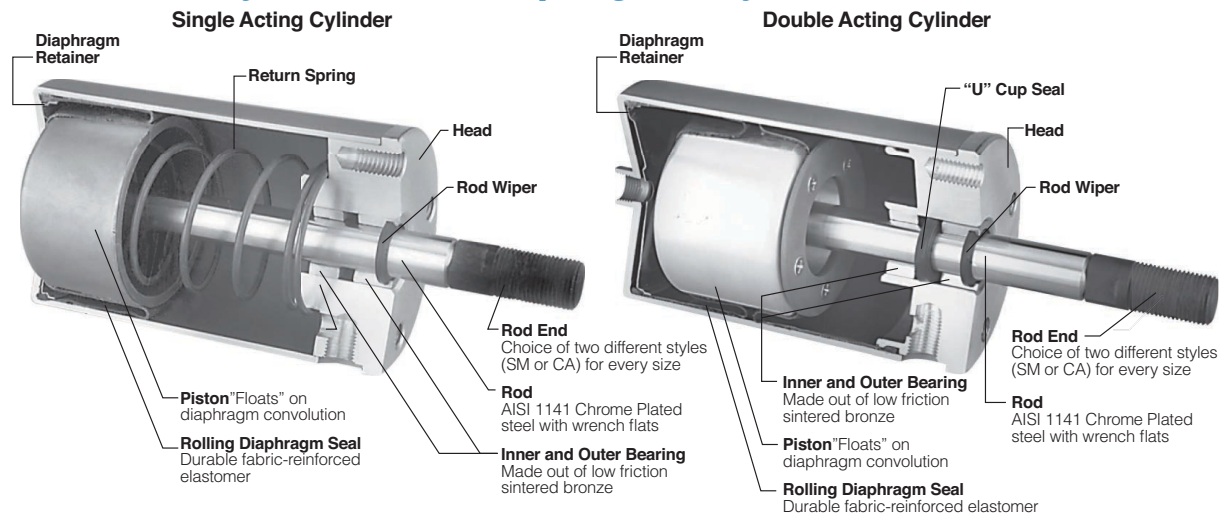

Rolling Diaphragm Air Cylinders

Clevis Bracket Stud / Clevis Bracket Mount

Dimensions

Cylinder Model	CL	EE	RD	B	CA Rod End				SM Rod End				J	H	I	G	A	F
					RL	RE	XD	RT	RL	RE	XD	RT						
Single Acting Cylinders																		
S-4-L	4.34	1/4 npt	1/2	.625	2.73	1.98	8.45	3/8-24	2.73	1.73	8.20	7/16-20	1/4	2.38	3.12	1.38	2.125	.93
S-6-L	5.28	1/4 npt	1/2	.625	2.69	1.94	9.35	3/8-24	2.69	1.69	9.09	7/16-20	1/4	2.38	3.12	1.38	2.125	.93
S-9-S	5.31	1/4 npt	3/4	.750	2.92	1.92	9.98	1/2-20	2.92	1.80	9.86	3/4-16	1/4	3.00	4.00	1.69	2.750	.99
S-9-L	6.34	1/4 npt	3/4	.750	2.69	1.69	10.80	1/2-20	2.69	1.57	10.67	3/4-16	1/4	3.00	4.00	1.69	2.750	.99
S-12-S	5.31	3/8 npt	3/4	.750	2.92	1.92	10.23	1/2-20	2.92	1.80	10.11	3/4-16	1/2	3.00	4.00	1.75	3.00	1.24
S-12-L	7.28	3/8 npt	3/4	.750	2.95	1.95	12.23	1/2-20	2.95	1.83	12.11	3/4-16	1/2	3.00	4.00	1.75	3.00	1.24
S-16-S	6.03	3/8 npt	3/4	.750	3.06	2.06	11.09	1/2-20	3.06	1.94	10.97	3/4-16	1/2	3.00	4.00	1.75	3.00	1.24
S-16-L	8.38	3/8 npt	3/4	.750	2.78	1.78	13.16	1/2-20	2.78	1.66	13.03	3/4-16	1/2	3.00	4.00	1.75	3.00	1.24
Double Acting Cylinders																		
D-4-L	4.34	1/4 npt	1/2	.625	2.73	1.98	8.45	3/8-24	2.73	1.73	8.20	7/16-20	1/4	2.38	3.12	1.38	2.125	.93
D-9-L	6.43	1/4 npt	3/4	.750	2.69	1.69	10.76	1/2-20	2.69	1.57	10.67	3/4-16	1/4	3.00	4.00	1.69	2.750	.99
Ultra Cylinders with Linear Ball Bearings																		
US-4-L	4.34	1/4 npt	1/2	.625	3.10	2.35	8.82	3/8-24	3.10	2.10	8.57	7/16-20	1/4	2.38	3.12	1.38	2.125	.93
US-6-L	5.28	1/4 npt	1/2	.625	2.16	1.41	8.82	3/8-24	2.16	1.16	8.57	7/16-20	1/4	2.38	3.12	1.38	2.125	.93
US-9-L	6.34	1/4 npt	3/4	.750	3.50	2.50	11.60	1/2-20	3.50	2.38	11.47	3/4-16	1/4	3.00	4.00	1.69	2.750	.99
US-12-L	7.28	3/8 npt	3/4	.750	2.57	1.57	11.85	1/2-20	2.57	1.45	11.73	3/4-16	1/2	3.00	4.00	1.75	3.00	1.24
US-16-L	8.38	3/8 npt	3/4	.750	3.78	2.78	14.16	1/2-20	3.78	2.66	14.04	3/4-16	1/2	3.00	4.00	1.75	3.00	1.24

Model Numbering

Cylinder Model	Clevis Bracket Stud P/N	Clevis Bracket Mount P/N
S-4-L	4-CBS	4-CBM
S-6-L	6-CBS	6-CBM
S-9-S	9-CBS	9-CBM
S-9-L	9-CBS	9-CBM
S-12-S	12-CBS	12-CBM
S-12-L	12-CBS	12-CBM
S-16-S	16-CBS	16-CBM
S-16-L	16-CBS	16-CBM
D-4-L	4-CBS	4-CBM
D-9-L	9-CBS	9-CBM
US-4-L	4-CBS	4-CBM
US-6-L	6-CBS	6-CBM
US-9-L	9-CBS	9-CBM
US-12-L	12-CBS	12-CBM
US-16-L	16-CBS	16-CBM

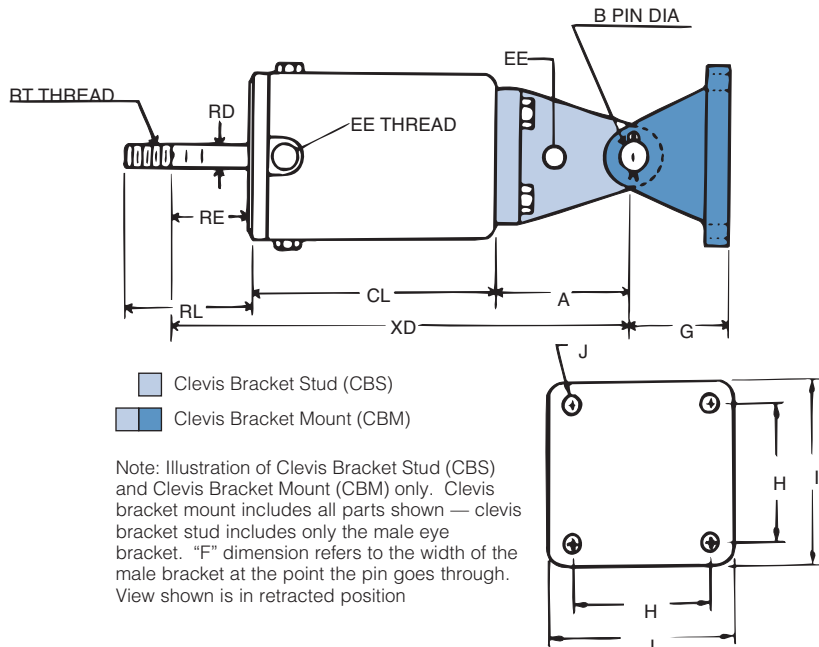

Note: Mounts ordered as separate items

Rolling Diaphragm Air Cylinders

Foot Mount

Cylinder Model	Foot Mount P/N								CA Rod End					SM Rod End					
		A	B	C	D	E	F	G	TL	X	RT	XA	ZB	H	TL	X	RT	XA	ZB
Single Acting Cylinders																			
S-4-L	4-FM	.380	1.125	1.500	.312	2.00	2.625	1.88	.75	2.41	3/8-24	7.44	7.94	6.59	1.00	2.41	7/16-20	7.19	7.69
S-6-L	6-FM	.380	1.125	1.500	.312	2.00	2.625	1.88	.75	2.38	3/8-24	8.35	8.84	7.53	1.00	2.38	7/16-20	8.10	8.59
S-9-S	9-FM	.500	1.625	2.375	.562	3.00	4.00	2.75	1.00	2.24	1/2-20	8.86	9.67	8.56	1.12	2.24	3/4-16	8.74	9.55
S-9-L	9-FM	.500	1.625	2.375	.562	3.00	4.00	2.75	1.00	2.06	1/2-20	9.67	10.41	9.59	1.12	2.06	3/4-16	9.55	10.28
S-12-S	12-FM	.500	1.625	2.375	.562	3.00	4.00	2.75	1.00	2.30	1/2-20	8.86	9.68	8.56	1.12	2.30	3/4-16	8.73	9.56
S-12-L	12-FM	.500	1.625	2.375	.562	3.00	4.00	2.75	1.00	2.33	1/2-20	10.86	11.68	10.53	1.12	2.33	3/4-16	10.73	11.48
S-16-S	16-FM	.500	1.625	2.375	.562	3.00	4.00	2.75	1.00	2.31	1/2-20	9.72	10.54	9.28	1.12	2.34	3/4-16	9.59	10.34
S-16-L	16-FM	.500	1.625	2.375	.562	3.00	4.00	2.75	1.00	2.16	1/2-20	11.78	12.53	11.62	1.12	2.16	3/4-16	11.66	12.40

Double Acting Cylinders																			
D-4-L	4-FM	.380	1.125	1.500	.312	2.00	2.625	1.88	.75	2.41	3/8-24	7.44	7.94	6.59	1.00	2.41	7/16-20	7.19	7.69
D-9-L	9-FM	.500	1.625	2.375	.562	3.00	4.00	2.75	1.00	2.99	1/2-20	9.67	10.41	9.59	1.12	2.06	3/4-16	9.55	10.28

Ultra Cylinders with Linear Ball Bearings																			
US-4-L	4-FM	.380	1.125	1.500	.312	2.00	2.625	1.88	.75	2.72	3/8-24	7.81	8.30	6.59	1.00	2.78	7/16-20	7.56	8.06
US-6-L	6-FM	.380	1.125	1.500	.312	2.00	4.00	1.88	.75	1.78	3/8-24	7.82	8.30	7.53	1.00	1.85	7/16-20	7.57	8.06
US-9-L	9-FM	.500	1.625	2.375	.562	3.00	4.00	2.75	1.00	3.00	1/2-20	10.48	11.21	9.59	1.12	2.87	3/4-16	10.36	11.09
US-12-L	12-FM	.500	1.625	2.375	.562	3.00	4.00	2.75	1.00	2.07	1/2-20	11.41	11.30	10.53	1.12	1.95	3/4-16	10.35	11.40
US-16-L	16-FM	.500	1.625	2.375	.562	3.00	4.00	2.75	1.00	3.28	1/2-20	12.78	13.53	11.62	1.12	3.16	3/4-16	12.66	13.40

Note: Mounts ordered as separate items.

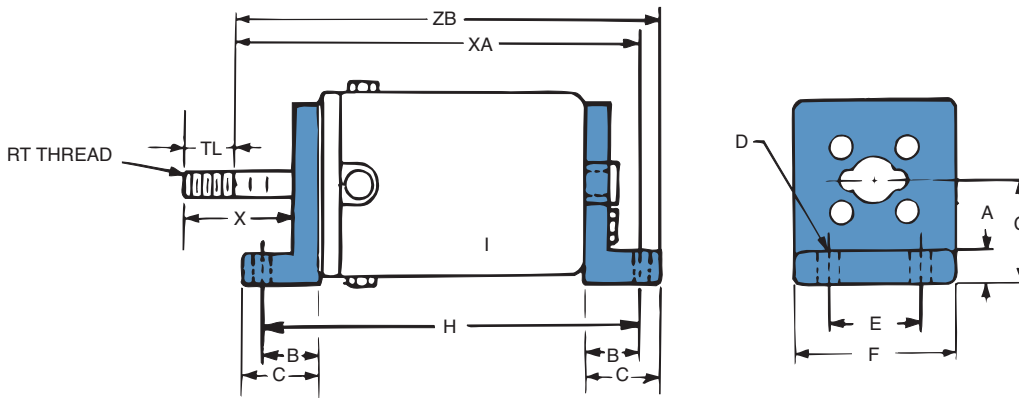

■ Foot Mount (FM)

Note: Illustration of footmount only. View shown is in retracted position.

Rolling Diaphragm Air Cylinders

Rod Clevis Mount

Two styles available to match rod thread—CA or SM. Must be ordered as a separate item.

Dimensions (Inches)

	4-L	6-L	9-S	9-L	12-S	12-L	16-S	16-L
CA - ControlAir Standard								
(CT) Clevis Thread	3/8-24	3/8-24	1/2-20	1/2-20	1/2-20	1/2-20	1/2-20	1/2-20
(CE) Clevis Extension	1-15/16	1-15/16	1-15/16	1-15/16	1-15/16	1-15/16	1-15/16	1-15/16
(PS) Pin Spacing	1.25	1.25	1.25	1.25	1.25	1.25	1.25	1.25
(CW) Clevis Width	1.38	1.38	1.38	1.38	1.38	1.38	1.38	1.38
(CB) Clevis Gap	.56	.56	.56	.56	.56	.56	.56	.56
(CD) Pin Diameter 1/2	1/2	1/2	1/2	1/2	1/2	1/2	1/2	1/2
(NH) Nut Height	7/32	7/32	5/16	5/16	5/16	5/16	5/16	5/16
(ND) Width Across Flats	9/16	9/16	3/4	3/4	3/4	3/4	3/4	3/4
SM --*NFPA Standard								
(CT) Clevis Thread	7/16-20	7/16-20	3/4-16	3/4-16	3/4-16	3/4-16	3/4-16	3/4-16
(CE) Clevis Extension	1-15/16	1-15/16	2-3/8	2-3/8	2-3/8	2-3/8	2-3/8	2-3/8
(PS) Pin Spacing	1.25	1.25	1.25	1.25	1.25	1.25	1.25	1.25
(CW) Clevis Width	1.38	1.38	2.50	2.50	2.50	2.50	2.50	2.50
(CB) Clevis Gap	.56	.56	1.25	1.25	1.25	1.25	1.25	1.25
(CD) Pin Diameter	1/2	1/2	3/4	3/4	3/4	3/4	3/4	3/4
(NH) Nut Height	1/4	1/8	27/64	27/64	27/64	27/64	27/64	27/64
(ND) Width Across Flats	11/16	11/16	1-1/8	1-1/8	1-1/8	1-1/8	1-1/8	1-1/8

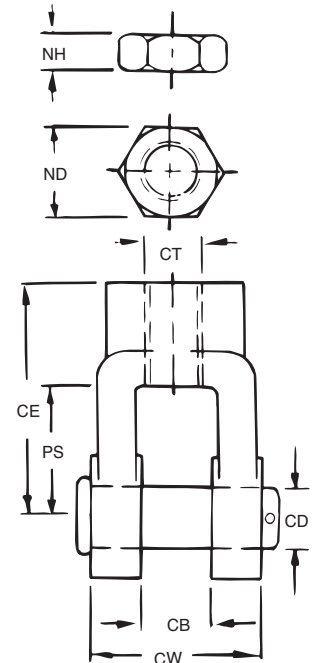

Note: Illustration shown attached to rod.

Ordering Information Example: 12 — CA — RC (1) (2) (3)

(1) Cylinder Size: Area in sq. in.
4, 5, 9, 12, 16

(2) Rod End Thread Size: CA (ControlAir Standard)
SM (NFPA Standard)

(3) Mount Type: RC indicates Rod Clevis Mount

Cylinder Cap End Mounting Studs

Cap end mounting studs are supplied when required by mount accessory selected (Clevis Bracket Stud, Clevis Bracket Mount, Foot Mount) or when specifically requested by customer (WITH STUDS). If mounting studs on the cap end are NOT desired add "NO STUDS" to end of ordering data. Not all sizes available as "no studs". Consult factory for availability.

	Cylinder Size							
	4-L	6-L	9-S	9-L	12-S	12-L	16-S	16-L
# Cap Studs	2	2	4	4	4	4	4	4
(BC) Bolt Circle of Studs	1-15/16	1-1/2	2	2	2-5/16	2-5/16	2-5/16	2-5/16
(HS) Height of Studs	5/8	5/8	5/8	5/8	5/8	5/8	5/8	5/8
(SS) Stud Size	1/4-20	1/4-20	1/4-20	1/4-20	1/4-20	1/4-20	3/8-16	3/8-16
(BD) Boss Diameter	11/16	11/16	11/16	11/16	1	1	1	1
(BH) Boss Height	13/32	13/32	13/32	13/32	17/32	17/32	17/32	17/32
(BR) Bolt Circle Retainer Nuts	1-3/8	1-3/8	1-3/8	1-3/8	1-11/16	1-11/16	1-11/16	1-11/16
(AN) Angle (Degrees)	90	90	45	45	45	45	45	45

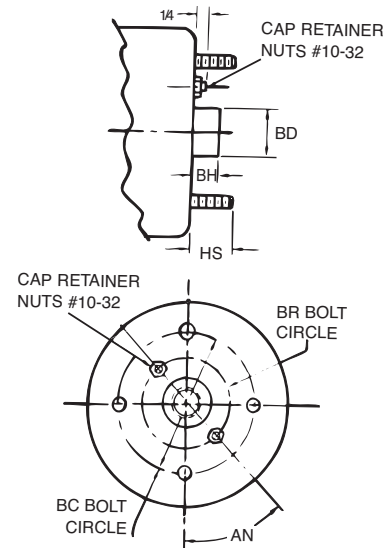

Rolling Diaphragm Air Cylinders

Mini Might

The MiniMights offer the same friction free performance as ControlAir's larger sized diaphragm air cylinders. These cylinders are highly sensitive with low hysteresis. They are available with threaded or unthreaded rod ends, flush or extended.

Specifications	MM-1	MM-2
	349-180-007	349-180-009
Stroke	0.70"	0.70"
Effective Pressure Area	0.384 sq. in.	0.384 sq. in.
Bore	0.7"	0.7"
Spring Load ("0" Stroke)	2 lbs.	2 lbs.
Spring Load (Max Stroke)	7 lbs.	7 lbs.
Max Operating Pressure	125 psi	125 psi
Dimensions		
L	2.81"	2.81"
N	0.438"	0.438"
W	15/16"	15/16"
D	7/8"	7/8"
Nose Mount Thread Size	1/2"-20 UNF	1/2"-20 UNF
Rod Diameter	1/4"	1/4"
Rod Extension	Flush	3/4"
Rod Thread	—	1/4"-28 UNF
Pipe Connection	1/8"-27 NPSF	1/8"-27 NPSF

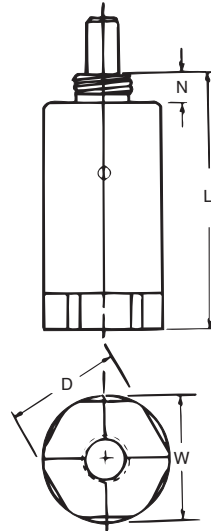

Materials: Aluminum Alloy Cylinder, Polyester Fabric Reinforced Nitrile Diaphragm, Treated Steel Rod, Music Wire Spring, Sintered Bronze Bearing.

Compact Cylinders

Materials: Diecast aluminum cylinder and end cap. Chrome plated carbon steel rod. Oil impregnated bronze bearing. Polyester fabric reinforced Nitrile diaphragm. Music wire spring.

Specifications	Part No.	Part No.
	139-190-002	139-190-001
Stroke	1"	1 3/8"
Effective Pressure Area	1.7 in. ²	1.7 in. ²
Dimension A	2 29/32"	3 21/32"
Bore Equivalent	1.5"	1.5"
Spring Load ("0" Stroke)	4 lbs.	4 lbs.
Spring Load (Max Stroke)	8 lbs.	11 lbs.
Max Operating Pressure	125 psi	125 psi
Mounting Hole Sizes	1/4"-20 UNC	1/4"-20 UNC

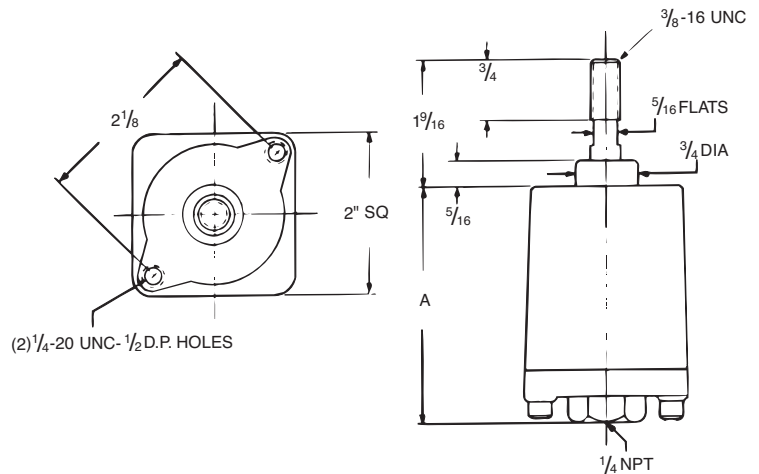

Rolling Diaphragm Air Cylinders

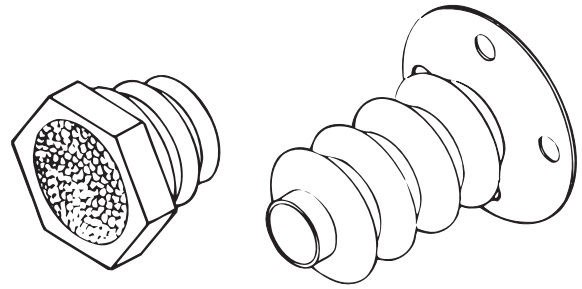

Repair Kits

Repair kits and replacement components are available from stock. All ControlAir kits and components are completely interchangeable with similar competitive cylinders already in the field. The repair kits consist of the following:

Spring Return Diaphragm Kit

1. Diaphragm
2. Adhesive Disk
3. Cap Retainer Sealing Nuts (2)
4. Instructions

Spring Return Bearing Kit

1. Inner Bearing
2. Outer Bearing
3. Rod Wiper Ring
4. Instructions

Double Acting Diaphragm Kit

1. Diaphragm, Cap
2. Diaphragm, Head
3. Retainer Adhesive, Cap
4. Retainer Adhesive, Head
5. Retaining Screws
6. Nuts, Cap Retainer
7. Seal "O" Ring
8. Tube, Silicone, Sealant

Double Acting Bearing Kit

1. Inner Bearing
2. Outer Bearing
3. Rod Wiper
4. U-Cup Seal
5. Instructions

Ultra Cylinder Bearing Kit

1. Linear Ball Bearing
2. Instructions

Cylinder Model	Diaphragm Kit #	Bearing Kit #
D-4-L	D4L	CAB-1/2-D
D-9-L	D9L	CAB-3/4-D
S-4-L	S4L	CAB-1/2
S-6-L	S6L	CAB-1/2
S-9-S	S9S	CAB-3/4
S-9-L	S9L	CAB-3/4
S-12-S	S12S	CAB-3/4
S-12-L	S12L	CAB-3/4
S-16-S	S16S	CAB-3/4
S-16-L	S16L	CAB-3/4
S-36-S	S36S	CAB-1
US-4-L	S4L	US-CAB-1/2
US-6-L	S6L	US-CAB-1/2
US-9-L	S9L	US-CAB-3/4
US-12-L	S12L	US-CAB-3/4
US-16-L	S16L	US-CAB-3/4

Accessories

Breather Vents Are used to prevent contamination from being drawn into the air relief port on the side of the cylinder head during the return stroke of the single acting cylinders. The BVF consists of a 40 micron bronze filter and is installed by threading into the side relief port.

To order: BVF-1 Fits cylinder sizes 4, 6, 9. 1/4" pipe tap.
BVF-2 Fits cylinder sizes 12, 16. 3/8" pipe tap.

Protective Bellows Are used for No Bearing or Ultra Cylinder applications to prevent contaminants from being drawn in through the cylinder head. The flange of the bellows is trimmed to accommodate the mounting configuration on the face of the cylinder head.

To order: PB-1 Fits cylinder sizes 4, 6. 2" bolt circle.
PB-2 Fits cylinder sizes 9, 12, 16. 3" bolt circle.
Mount Kit for PB-1: P/N 149-400-019
Mount Kit for PB-2: P/N 149-400-021

Limited Warranty & Disclaimer

ControlAir, Inc. products are warranted to be free from defects in materials and workmanship for a period of one year from the date of sale, provided said products are used according to Control Air, Inc. recommended usages. ControlAir, Inc.'s liability is limited to repair of, refund of purchase paid for, or replacement in kind of, at ControlAir, Inc.'s sole option, any products proved defective. ControlAir, Inc. reserves the right to discontinue manufacture of any products or change products materials, design or specifications without notice.

Warning

These products are intended for use in industrial compressed-air systems only. Do not use these products where pressures and temperatures can exceed those listed under Specifications. Before using these products with fluids other than air, for non-industrial applications, life-support systems, or other applications not within published specifications, consult ControlAir, Inc.



8 Columbia Drive / Amherst, NH 03031 USA / www.controlair.com / sales@controlair.com / 603-886-9400 / FAX 603-889-1844

An ISO-9001:2008 Certified Company

P/N 441-625-012 11/17